



# **MINIDUMPERS**

DK-EN







# C&F - CONSTRUCTION EQUIPMENT

[www.cfequipments.com](http://www.cfequipments.com)

**DA** I 2002 blev C&F grundlagt som et produktionsselskab for komponenter til betjenings- og løftmaskiner efter 30 års erfaring inden for jordbearbejdningsmaskineri. Fra og med 2008 begyndte produktionen af udstyr til minilæssere, teleskoplæssere, læssemaskiner, rendegravere og gravemaskiner og minidumpere med larvebånd af mærket C&F.

## —Værdier

Fra begyndelsen har firmaet været kendetegnet af et innovativt Drive: C&F tilbyder nye løsninger som fremmer anvendelighed, sikkerhed og ydeevne af maskiner og tilbehør. Ved at lytte til slutbruger, forhandlere og udlejningsfirmaer, får vi input som hjælper os til vedholdende at investere i udforskning og udvikling af avancerede løsninger, så kan tilpasse os vores kunders behov øjeblikkeligt.

## —Kvalitet

Vi designer og producerer alle vores produkter internt, fordi vi stærkt tror på vores ideer og kvaliteten af den italienske produktion. Vi vælger de bedste materialer og komponenter til alle vores maskiner for at sikre maksimal holdbarhed over tiden.

## —Sortiment

Sortimentet af minidumpere omfatter 6 modeller opdelt efter kapacitet fra 450 kg til 1500 kg i over 40 forskellige kombinationer af udstyr og motorer. Alle modellerne er kendetegnet ved innovative tekniske løsninger, der garanterer holdbarhed over tiden og pålidelighed selv under de mest krævende arbejdsvilkår.

**EN** C&F was founded in 2002 as a company manufacturing moving and lifting machine components, after over 30 years of experience in the earthmoving field. Since 2008, the company has launched the production of equipment for skid steer loaders, telehandlers, backhoe loaders, wheel loaders and excavators, and the own-brand tracked minidumpers.

## —Value

From the beginning, the company has been characterized by an innovative drive: C&F offers new solutions to improve use, safety and performance of its machines and applications. Listening to end-users, dealers and rental companies helps us to improve and invest constantly in research and development of advanced solutions able to promptly respond to our customer needs.

## —Quality

C&F designs and produces all the product range internally, as we strongly believe in the strength of our ideas and in the quality of Italian manufacture. We accurately select the best materials and components for our equipment to guarantee maximum durability.

## —Products

The minidumper range includes 6 models divided by capacity, from 450 kg to 1500 kg, in over 40 different combinations of equipment and engine. All models stand out for innovative technical solutions that guarantee resistance in time and reliability in any working condition.

**C&F SRL**  
**Viale Finlandia 8**  
**73100 Lecce, IT**  
**VAT 036 19 66 07 50**



## C&F · MINIDUMPERS



**DA** Dumperen med larvebånd er det ideelle multifunktionelle middel til brug på byggepladser eller på vanskeligt tilgængelige steder, hvor gummidumperne bevæger sig med besvær. De er udviklet til at transportere et hvilket som helst materiale uden problemer på enhver overflade, som f.eks. mudret, sandet terræn eller ved stærkt hældende terræn fortil og til siden, som bjerge, idet den altid garanterer den maksimale stabilitet og sikkerhed.

Præstationer, kørekvalitet og driftssikkerhed er de tre vigtigste punkter, som disse små maskiner er udviklet efter. Hele serien er udviklet til på samme tid at garantere kraft, kontrol og gode bevægelsesegenskaber og præsenteres på markedet i de mest reducerede dimensioner.

Med fokus på forskning og innovation er dumperne fra og med modellen T85 udstyret med et monojoystick med hydraulisk styring af maskinens tværgående bevægelse og rotation. Enestående af sin art garanterer dette system for modellerne med en kapacitet fra 800 kg til 1.500 kg en yderst enkelt styring, lavt forbrug og hurtig kørsel uden nogensinde at gå på kompromis med præstationen.

**EN** The tracked dumper is the perfect multi-tool machine, aimed to the use in construction sites or in barely accessible areas where wheeled dumpers move with difficulty. It is designed to easily carry any material on any kind of surface, such as muddy or sandy terrains, or in strong front and side sloping conditions such as mountain areas, always guaranteeing maximum stability and safety. Performance, driving quality and reliability are the three focal points which the design of these machines is based on.

The entire range is developed to guarantee power, movement control and agility, showing to the market the smallest-sized products.

Thanks to investments in research and innovation, starting from T85 model, all dumpers from 1763 lbs to 3306 lbs capacity are equipped with a mono-joystick with hydraulic control, dedicated to machine translation and rotation. Unique of its kind, this system ensures precise movements, low consumption and short travel times, never overlooking machine performances.

# TRAKER T45

450 kg · 992 lbs

**DA** Minidumperen T45 med maksimal kapacitet på 450 kg er den mindste professionelle maskine i serien. Lavt tryk på jorden og meget reducerede dimensioner giver denne maskine mulighed for at arbejde på meget snæver plads og på et hvilket som helst terræn.

**EN** T45 minidumper has 992 lbs capacity and it is the smallest professional machine of the product range. Low ground pressure and very small dimensions enable this machine to work in the narrowest spaces on any kind of terrain.

Overbygning  
Extra overboard



Udstyret med / Equipped with:  
Honda 5.5 HP – Yanmar 4.7 HP



T45 • MINIDUMPER

C&F—CONSTRUCTION EQUIPMENT





1	2	3
Diesel-eller benzinmotor Gasoline or diesel engine	Manuel eller elektrisk start Manual or electric starting	To hydrauliske pumper med tandhjulsudveksling Two hydraulic gear pump
4	5	
Hydrostatisk transmission Hydrostatic transmission	Oscillerende ruller Rocking rollers	

**FORDELE/ ADVANTAGES**



Ergonomisk og sikkert håndtag  
Ergonomic handle-bar

Oscillerende ruller  
Rocking rollers

Enkle og intuitive betjeningsanordninger  
Easy and intuitive controls

Parkeringsbremse  
Emergency brake

# TRAKER T45

MINIDUMPER

DRIFTSKAPACITET  
OPERATING WEIGHT  
450 kg · 992 lbs

MASKINENS BREDDE  
MACHINE WIDTH  
680 mm · 26.7 inch

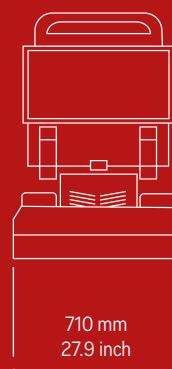
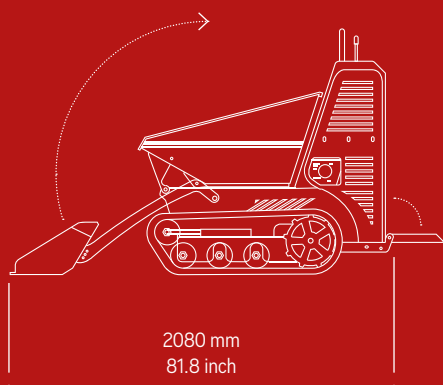
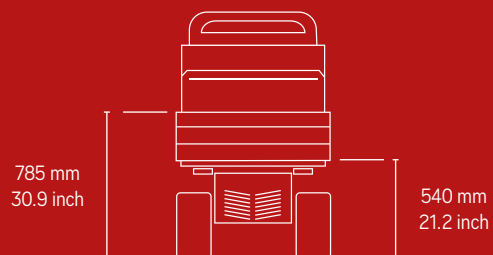
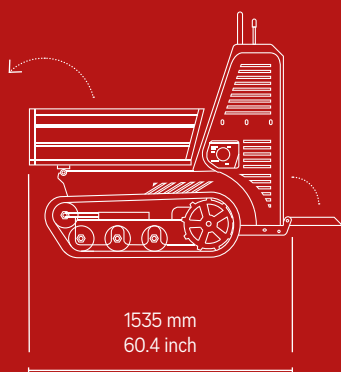
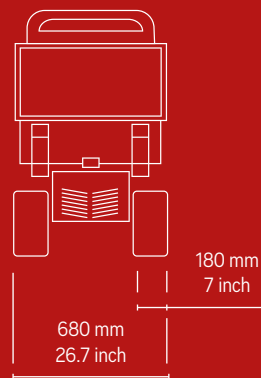
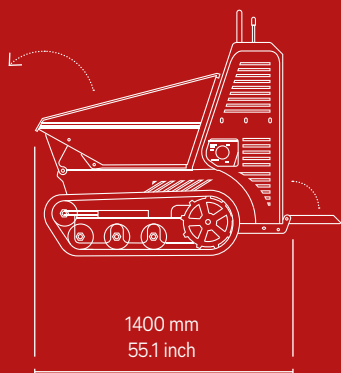

**MOTOR  
ENGINE**

→ HONDA GX200  
→ YANMAR L48N

**TRANSMISSION  
TRASMISSION**

→ HYDROSTATISK  
→ HYDROSTATIC

**HYDRAULISK PUMPE  
HYDRAULIC PUMP**

2 x TANDHJULSUDVEKSLINGER  
2 x GEAR PUMP

**HYDRAULISK MOTOR  
HYDRAULIC MOTOR**

2 x BANER  
2 x ORBITAL

**PUMPEKAPACITET  
PUMP FLOW RATE**

2 × 14 l/min  
2 × 3.8 gpm

**MAKSIMALT TRYK  
MAX PRESSURE**

180 bar

**HYDRAULISK KØLING  
HYDRAULIC COOLING SYSTEM**

LUFT  
AIR

**BREDDE LARVEBÅND  
TRACK WIDTH**

180 mm  
7 inch

**RULLER  
TRACK ROLLERS**

3

**OSCILLERENDE RULLER  
ROCKING ROLLERS**

→ JA  
→ YES

**REGULERING LARVEBÅND  
TRACK TENSIONER**

JA  
YES

**1 MARCH HASTIGHED  
1 TRAVEL SPEED**

2,5 km/t  
1.55 mp/h

**DRIFTSKAPACITET  
OPERATING WEIGHT**

→ 450 kg  
→ 992 lbs

**EGENVÆGT  
EMPTY WEIGHT**

340 kg  
749 lbs

**TEKNISKE SPECIFIKATIONER / TECHNICAL FEATURES**



FYLDT TIL RANDEN  
0,22 m<sup>3</sup>  
STRUCK 0.28 yd<sup>3</sup>

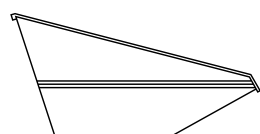

FYLDT OVER RANDEN  
0,29 m<sup>3</sup>  
HEAPED 0.37 yd<sup>3</sup>

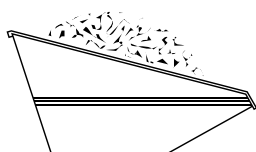

FYLDT TIL RANDEN  
0,15 m<sup>3</sup>  
STRUCK 0.19 yd<sup>3</sup>

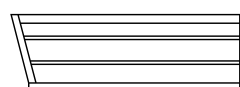

FYLDT OVER RANDEN  
0,23 m<sup>3</sup>  
HEAPED 0.30 yd<sup>3</sup>

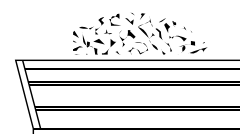

**KAPACITET / CAPACITY**

# TRAKER T50

500 kg · 1102 lbs

**DA** Dobbelt hastighed af tværgående bevægelse og tredobbelt hydraulisk pumpe kendetegner modellen T50. Med en kapacitet på 500 kg er minidumperen ideel til arbejde på blødt eller ujævnt terræn. Takket være den anden hastighed kan håndteringen af materialerne på byggepladsen gøres meget hurtigere.

**EN** Double-speed of translation and triple hydraulic pump distinguish T50 model. With its 1102 lbs capacity, it is the ideal minidumper to work on soft or rough ground and, thanks to the second speed, it is possible to accelerate material handling times into construction sites.

Selvæssende system  
Self-loading system



Udstyret med / Equipped with:  
Honda 5.5 HP

Affjedret platform  
Soften foot-plate



T50 • MINIDUMPER

C&F - CONSTRUCTION EQUIPMENT



<p>1</p> <p>Benzinmotor Gasoline engine</p>	<p>2</p> <p>Manuel eller elektrisk start Manual or electric starting</p>	<p>3</p> <p>Tre hydrauliske pumper med tandhjulsudveksling Three hydraulic gear pump</p>
<p>4</p> <p>Hydrostatisk transmission Hydrostatic transmission</p>	<p>5</p> <p>Oscillerende ruller Rocking rollers</p>	

**FORDELE/ ADVANTAGES**



Forstærket kasse  
Heavy duty bucket

Kasse med sider, der kan åbnes  
Farm bed skip



Dobbelt hastighed af tværgående bevægelse  
Double travel speed

Ergonomisk og sikkert håndtag  
Ergonomic handle-bar



# TRAKER T50

MINIDUMPER

DRIFTSKAPACITET  
OPERATING WEIGHT  
500 kg · 1102 lbs

MASKINENS BREDDE  
MACHINE WIDTH  
680 mm · 26.7 inch

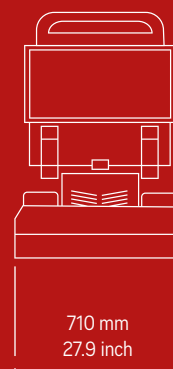
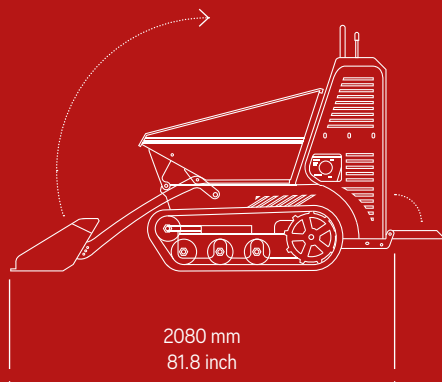
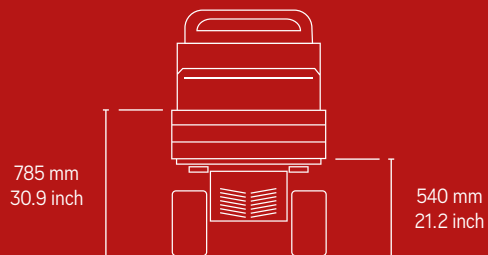
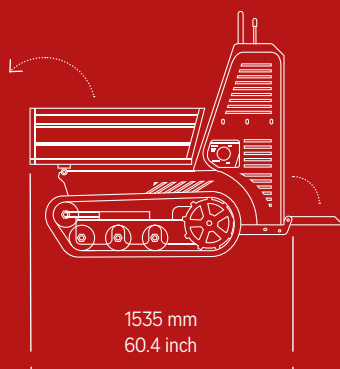
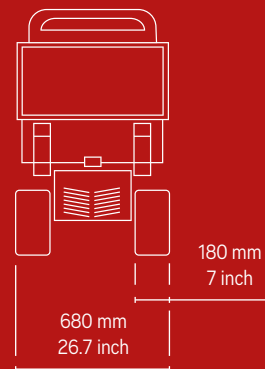
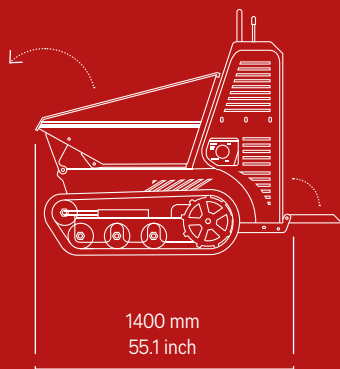

<b>MOTOR</b> <b>ENGINE</b> → HONDA GX200	<b>TRANSMISSION</b> <b>TRASMISSION</b> → HYDROSTATISK → HYDROSTATIC	<b>HYDRAULISK PUMPE</b> <b>HYDRAULIC PUMP</b> → 3 X TANDHJULSUDVEKSLINGER → 3 X GEAR PUMP
<b>HYDRAULISK MOTOR</b> <b>HYDRAULIC MOTOR</b> 2 x BANER 2 x ORBITAL	<b>PUMPEKAPACITET</b> <b>PUMP FLOW RATE</b> 3 × 14 l/min 3 × 3.8 gpm	<b>MAKSIMALT TRYK</b> <b>MAX PRESSURE</b> 180 bar
<b>HYDRAULISK KØLING</b> <b>HYDRAULIC COOLING SYSTEM</b> LUFT AIR	<b>BREDDE LARVEBÅND</b> <b>TRACK WIDTH</b> 180 mm 7 inch	<b>RULLER</b> <b>TRACK ROLLERS</b> 3
<b>OSCILLERENDE RULLER</b> <b>ROCKING ROLLERS</b> → JA → YES	<b>REGULERING LARVEBÅND</b> <b>TRACK TENSIONER</b> JA YES	<b>2 MARCH HASTIGHED</b> <b>2 TRAVEL SPEED</b> 2,5 – 3,5 km/t 1.55 – 2.2 mp/h
<b>DRIFTSKAPACITET</b> <b>OPERATING WEIGHT</b> → 500 kg → 1102 lbs	<b>EGENVÆGT</b> <b>EMPTY WEIGHT</b> 340 kg 749 lbs	

**TEKNISKE SPECIFIKATIONER / TECHNICAL FEATURES**

 FYLDT TIL RANDEN  
0,22 m<sup>3</sup>  
STRUCK 0.28 yd<sup>3</sup>

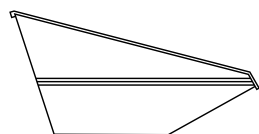

 FYLDT OVER RANDEN  
0,29 m<sup>3</sup>  
HEAPED 0.37 yd<sup>3</sup>

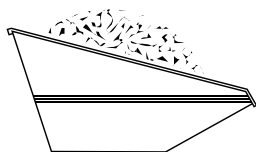

 FYLDT TIL RANDEN  
0,15 m<sup>3</sup>  
STRUCK 0.19 yd<sup>3</sup>

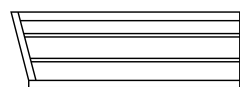

 FYLDT OVER RANDEN  
0,23 m<sup>3</sup>  
HEAPED 0.30 yd<sup>3</sup>

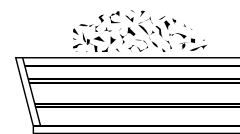

**KAPACITET / CAPACITY**

# TRAKER T60

600 kg · 1323 lbs

**DA** Termiske motorer med større ydeevne og en stor hydraulisk kraft giver minidumperen T60 mulighed for nemt at transportere last indtil 600 kg. Den ideelle maskine til brug på byggepladser, til havearbejde, landbrug og havedesign.

**EN** More effective thermal engine and a great three-stage hydraulic power ensure to T60 minidumper to carry easily up to 1323 lbs loads. The ideal machine to be used in construction sites, landscaping, agriculture or garden design.

Overbygning  
Extra overboard



Forstærket undervogn  
Heavy duty undercarriage



T60 • MINIDUMPER

C&F—CONSTRUCTION EQUIPMENT





1

Diesel- eller benzinmotor  
Gasoline or diesel engine

2

Manuel eller elektrisk start  
Manual or electric starting

3

Tre hydrauliske pumper med  
tandhjulsudveksling  
Three hydraulic gear pumps

4

Hydrostatisk transmission  
Hydrostatic transmission

5

Oscillerende ruller  
Rocking rollers

**FORDELE/ ADVANTAGES**



Udstyret med / Equipped with:  
Honda 8.4 HP – Yanmar 6.7 HP

Maks. højde 1.420 mm  
Max height 55.9 inch



Instrumentbræt komplet med alle sikkerhedsanordninger  
Dashboard equipped with all the safety devices



# TRAKER T60

MINIDUMPER

DRIFTSKAPACITET  
OPERATING WEIGHT  
600 kg · 1323 lbs

MASKINENS BREDD  
MACHINE WIDTH  
680 mm · 26.7 inch

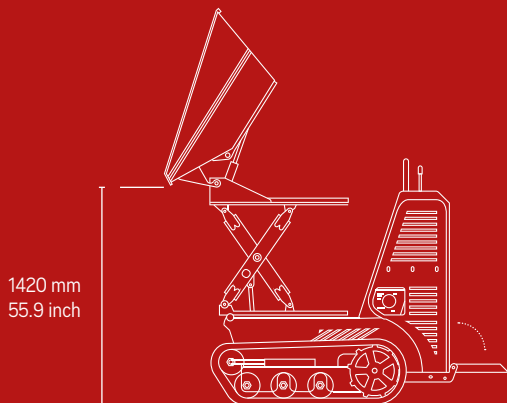
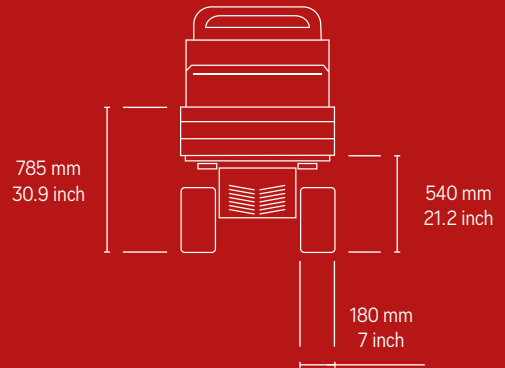
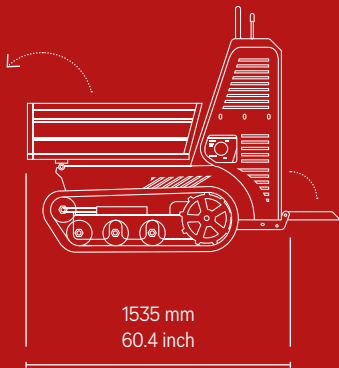
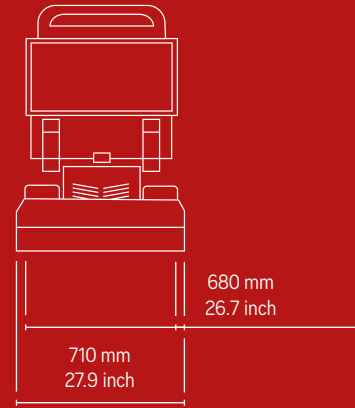
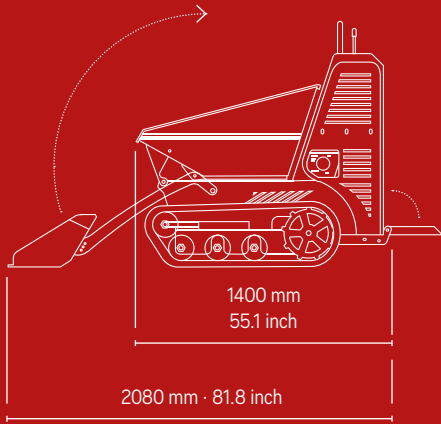

**MOTOR**  
**ENGINE**

→ HONDA GX270  
→ YANMAR L70N

**TRANSMISSION**  
**TRASMISSION**

→ HYDROSTATISK  
→ HYDROSTATIC

**HYDRAULISK PUMPE**  
**HYDRAULIC PUMP**

→ 3 X TANDHJULSUDVEKSLINGER  
→ 3 X GEAR PUMP

**HYDRAULISK MOTOR**  
**HYDRAULIC MOTOR**

2 x BANER  
2 x ORBITAL

**PUMPEKAPACITET**  
**PUMP FLOW RATE**

3 × 14 l/min  
3 × 3.8 gpm

**MAKSIMALT TRYK**  
**MAX PRESSURE**

180 bar

**HYDRAULISK KØLING**  
**HYDRAULIC COOLING SYSTEM**

LUFT  
AIR

**BREDDE LARVEBÅND**  
**TRACK WIDTH**

180 mm  
7 inch

**RULLER**  
**TRACK ROLLERS**

3

**OSCILLERENDE RULLER**  
**ROCKING ROLLERS**

→ JA  
→ YES

**REGULERING LARVEBÅND**  
**TRACK TENSIONER**

JA  
YES

**2 MARCH HASTIGHED**  
**2 TRAVEL SPEED**

2,5 – 3,5 km/t  
1.55 – 2.2 mp/h

**DRIFTSKAPACITET**  
**OPERATING WEIGHT**

→ 600 kg / 1323 lbs

**HIGH-TIP**

→ 500 kg / 1102 lbs

**EGENVÆGT**  
**EMPTY WEIGHT**

355 kg  
749 lbs

**TEKNISKE SPECIFIKATIONER / TECHNICAL FEATURES**



FYLDT TIL RANDEN  
0,23 m<sup>3</sup>  
STRUCK 0.28 yd<sup>3</sup>

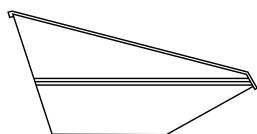

FYLDT OVER RANDEN  
0,29 m<sup>3</sup>  
HEAPED 0.37 yd<sup>3</sup>

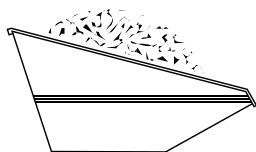

FYLDT TIL RANDEN  
0,15 m<sup>3</sup>  
STRUCK 0.19 yd<sup>3</sup>

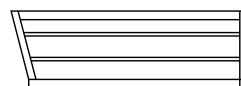

FYLDT OVER RANDEN  
0,23 m<sup>3</sup>  
HEAPED 0.30 yd<sup>3</sup>

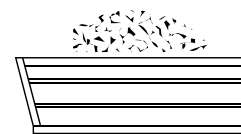

FYLDT TIL RANDEN  
0,18 m<sup>3</sup>  
STRUCK 0.23 yd<sup>3</sup>

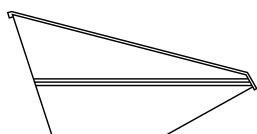

FYLDT OVER RANDEN  
0,23 m<sup>3</sup>  
HEAPED 0.30 yd<sup>3</sup>

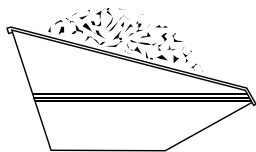

**KAPACITET / CAPACITY**

# TRAKER T85

800 kg · 1763 lbs

**DA** Unik på markedet er Traker T85 modellen med uforlignelige præstationer og egenskaber. Det har aldrig været så let at transportere op til 800 kg materiale. Den dobbelte pumpe med variabel kapacitet med monojoystick gør denne maskinen kraftig og nem at styre, reducerer forbruget og nulstiller vedligeholdelsesindgrebene. Det ideelle middel til stor arbejdsbelastninger og lejeflåde.

**EN** Unique of its kind, T85 minidumper has performances and features like no other. It's never been easier to carry up to 1763 lbs of material. The double variable-displacement pump with monojoystick hydraulic control makes this machine powerful and easy-to-use, reducing consumption and eliminating maintenance. It's the ideal dumper for high-duty activities and rental fleets.

Overbygning  
Extra overboard



Bageste motorhjelme med sideåbning  
for at lette vedligeholdelsesindgrebene  
Engine cover with side opening to facilitate maintenance



T85 • MINIDUMPER

C&F—CONSTRUCTION EQUIPMENT



<p>1</p> <p>Diesel-eller benzinmotor Gasoline or diesel engine</p>	<p>2</p> <p>Elektrisk start Electric starting</p>	<p>3</p> <p>To pumper med var. Kap. + 1 pumpeindgang Two pumps var. displ. + 1 gear pump</p>
<p>4</p> <p>Hydrostatisk transmission Hydrostatic transmission</p>		<p>5</p> <p>Oscillerende ruller Rocking rollers</p>

**FORDELE/ ADVANTAGES**



Udstyret med /Equipped with:  
Honda 11.7 HP – Yanmar 10 HP

Affjedret platform  
Soften foot-plate



Oscillerende ruller  
Rocking rollers

Lette og intuitive betjeningsanordninger  
Easy and intuitive controls

**> Monojoystick**

Den eneste minidumper på markedet med trækkontrol, der aktiveres af et servostyret hydraulisk monojoystick.

The only minidumper on the market with traction controlled by a servo hydraulic monojoystick.



# TRAKER T85

MINIDUMPER





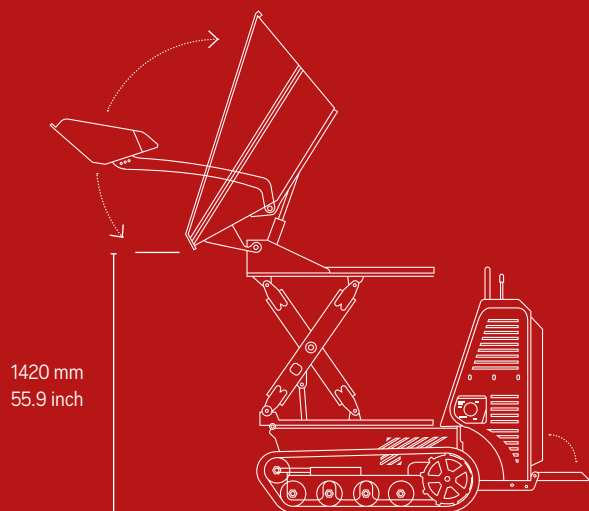
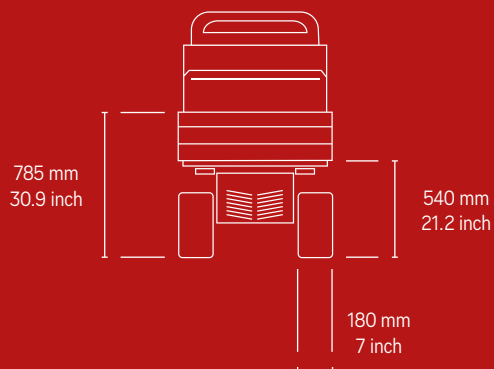
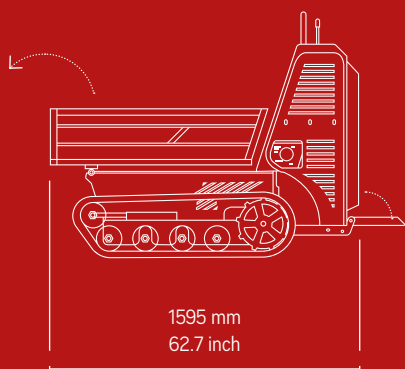
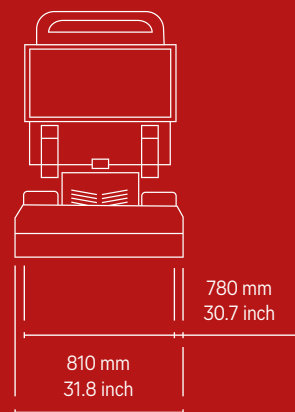
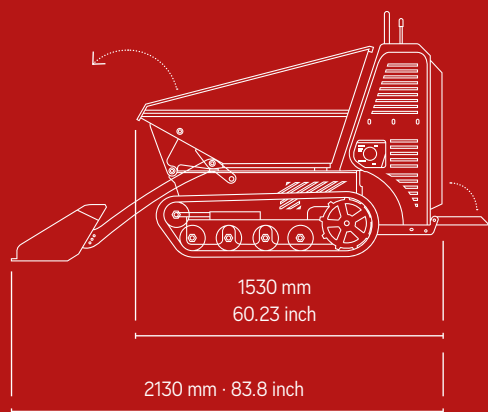





DRIFTSKAPACITET  
OPERATING WEIGHT  
800 kg · 1763 lbs

MASKINENS BREDDE  
MACHINE WIDTH  
780 mm · 27.9 inch

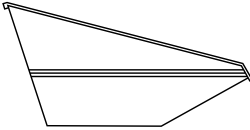

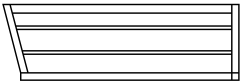
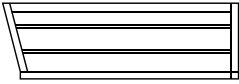
<b>MOTOR</b> <b>ENGINE</b> → HONDA GX390AE → YANMAR L100N	<b>TRANSMISSION</b> <b>TRASMISSION</b> → HYDROSTATISK → HYDROSTATIC	<b>HYDRAULISK PUMPE</b> <b>HYDRAULIC PUMP</b> → 2 x KAP. VAR. + 1 PUMPEINDGANG → 2 x VAR. DISPL. + 1 GEAR PUMP
<b>HYDRAULISK MOTOR</b> <b>HYDRAULIC MOTOR</b> 2 x BANER 2 x ORBITAL	<b>PUMPEKAPACITET</b> <b>PUMP FLOW RATE</b> → 2x32 l/min + 1 PUMPEINDGANG → 2x8.5 gpm + 1 GEAR PUMP	<b>MAKSIMALT TRYK</b> <b>MAX PRESSURE</b> 180 bar
<b>HYDRAULISK KØLING</b> <b>HYDRAULIC COOLING SYSTEM</b> LUFT AIR	<b>BREDDE LARVEBÅND</b> <b>TRACK WIDTH</b> 180 mm 7 inch	<b>RULLER</b> <b>TRACK ROLLERS</b> → 4
<b>OSCILLERENDE RULLER</b> <b>ROCKING ROLLERS</b> JA YES	<b>REGULERING LARVEBÅND</b> <b>TRACK TENSIONER</b> JA YES	<b>MARCH HASTIGHED</b> <b>TRAVEL SPEED</b> → 5 km/t → 3.1 mp/h
<b>DRIFTSKAPACITET</b> <b>OPERATING WEIGHT</b> → 800 kg / 1763 lbs <b>HIGH-TIP</b> → 700 kg / 1543 lbs	<b>EGENVÆGT</b> <b>EMPTY WEIGHT</b> 500 kg 1102 lbs	<b>STYRING</b> <b>CONTROL</b> → MONOJOYSTICK

**TEKNISKE SPECIFIKATIONER / TECHNICAL FEATURES**

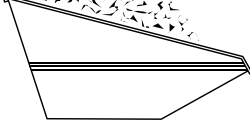
 FYLDT TIL RANDEN 0,30 m <sup>3</sup> STRUCK 0.39 yd <sup>3</sup>	 FYLDT OVER RANDEN 0,36 m <sup>3</sup> HEAPED 0.45 yd <sup>3</sup>	 FYLDT TIL RANDEN 0,17 m <sup>3</sup> STRUCK 0.22 yd <sup>3</sup>	 FYLDT OVER RANDEN 0,25 m <sup>3</sup> HEAPED 0.32 yd <sup>3</sup>
			
 FYLDT TIL RANDEN 0,28 m <sup>3</sup> STRUCK 0.37 yd <sup>3</sup>	 FYLDT OVER RANDEN 0,36 m <sup>3</sup> HEAPED 0.47 yd <sup>3</sup>		
			

**KAPACITET / CAPACITY**

# TRAKER T120 - 150

1200 kg · 2465 lbs  
1500 kg · 3305 lbs

**DA** T120 og T150 er en multitool maskine, som giver mulighed for at skifte udstyr på få minutter. Udviklet til "heavy duty" brug finder de anvendelse i byggesektoren og i alle sektorer med stort arbejdsomfang. Utrættelige og præcise maskiner takket være de kraftige motorer og det hydrauliske kontrolsystem med monojoystick.

**EN** T120 and T150 are the Multi-tool machines that permit to change equipment in few minutes. Designed for heavy-duty use, they find application in the construction field and in all the areas characterized by high workload. Endless and precise machines, thanks to powerful engines and to the hydraulic control system guided by a mono-joystick.



T120/150 - MINIDUMPER MULTI-TOOL

C&F - CONSTRUCTION EQUIPMENT





1

Lynfrakoblingsystem  
Quick coupling system

2

Køling med væske  
Liquid cooling

3

Køling med hydraulikolie  
Hydraulic oil cooling

4

Hydrostatisk transmission  
Hydrostatic transmission

5

Oscillerende ruller  
Rocking rollers

6

Dieselmotor Yanmar på 22 / 25 hk  
Yanmar diesel engine 22 / 25 hp

7 – Optional

Kraftudtag 50 l/min  
Power take (P.T.O) 13 gpm

**FORDELE/ ADVANTAGES**



A

Konisk centrering  
Conical centering system



B

Reduktionsgear med hydraulisk  
bremse  
Gearmotor with hydraulic brake



C

Båndstrammer med fedt  
Greased track tensioner



D

Beskyttet hydraulisk tilslutning  
Covered hydraulic connection



E

Dobbelte oscillerende ruller  
Double rocking-rollers



F

Lynblokering af tilbehør  
Equipment quick-locking



## > QUICK ATTACH

Quick attach er systemet, som gør det muligt at skifte maskinens funktion hurtigt og sikkert.

Quick-attach is the designed system to change promptly and safely the purpose of the machine.

Tilgængelige versioner · Available models

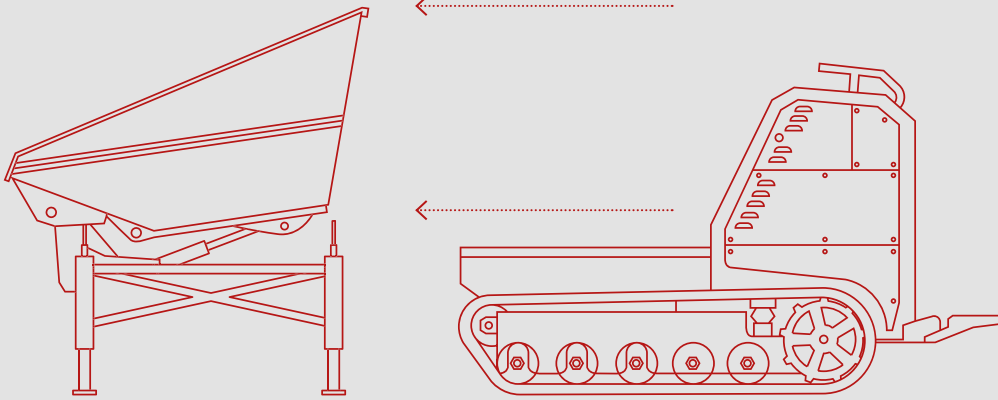

### **TRAKER T120**

Kapacitet / Capacity  
1200 Kg  
YANMAR 22 HP



### **TRAKER T150**

Kapacitet / Capacity 1500 Kg  
YANMAR 25 HP



Bageste motorhjelm med sideåbning til at lette vedligeholdelsesindgrebene  
Dashboard equipped with gauges and safety devices



Dobbelte oscillerende ruller  
Double rocking rollers

Lasteevne op til 1.500 kg  
Load capacity up to 1500 Kg



Instrumentbræt komplet med indikatorer og sikkerhedsanordninger  
Dashboard equipped with gauges and safety devices

## > Monojystick

Den eneste minidumper på markedet med trækkontrol, der aktiveres af et servostyret hydraulisk monojystick.

The only minidumper on the market with traction controlled by a servo hydraulic monojystick.



# TRAKER T120 - 150

MULTI-TOOL

DRIFTSKAPACITET  
OPERATING WEIGHT  
1200 · 1500 kg / 2465 · 3306 lbs

MASKINENS BREDDE  
MACHINE WIDTH  
910 · 940 mm / 35.8 · 37 inch

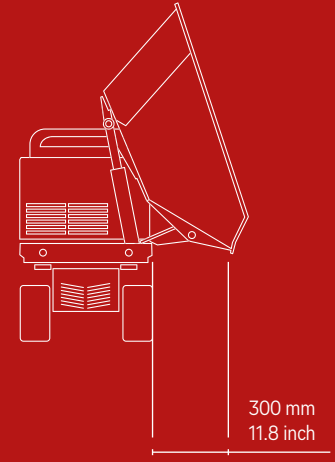
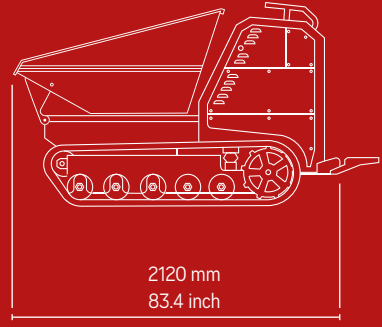
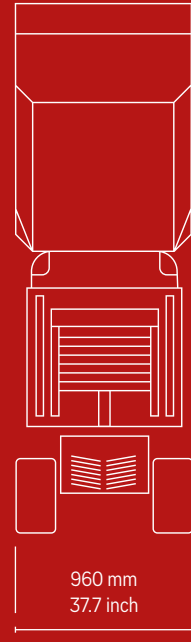
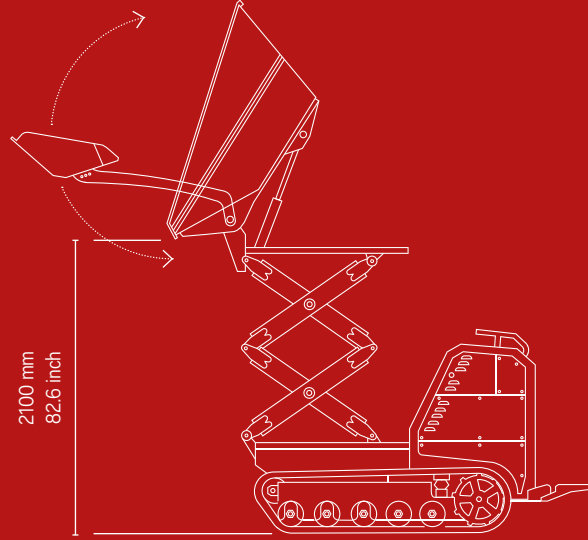
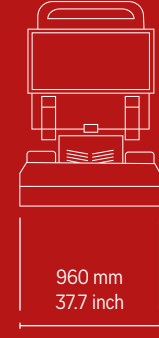
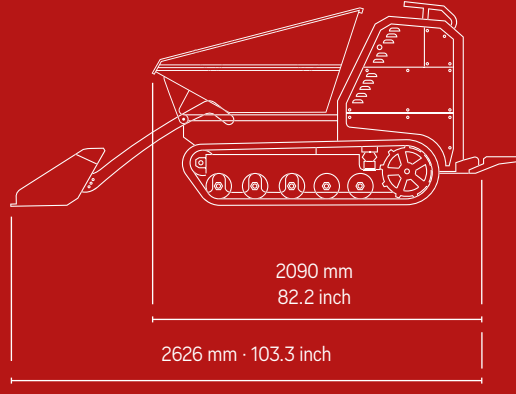

T120/150 • MINIDUMPER MULTI-TOOL

C&F—TEKNISKE SPECIFIKATIONER

**MOTOR**  
**ENGINE**

→ YANMAR 3TNV-70  
→ YANMAR 3TNV-76

**TRANSMISSION**  
**TRASMISSION**

→ HYDROSTATISK  
→ HYDROSTATIC

**HYDRAULISK PUMPE**  
**HYDRAULIC PUMP**

→ 2 KAP. VARIABLE + TANDHJULSUD-  
VEKSLINGER  
→ 2 VAR. DISPL. + 1 GEAR PUMP

**HYDRAULISK MOTOR**  
**HYDRAULIC MOTOR**

2 x REDUKTIONSGEAR  
2 x GEARBOX

**PUMPEKAPACITET**  
**PUMP FLOW RATE**

→ 2 × 56 l/min + 1 PUMPEINDGANG  
→ 2 x 15 gpm + 1 GEAR PUMP

**MAKSIMALT TRYK**  
**MAX PRESSURE**

180 bar

**HYDRAULISK KØLING**  
**HYDRAULIC COOLING SYSTEM**

VÆSKE  
LIQUID

**BREDDE LARVEBÅND**  
**TRACK WIDTH**

200 · 230 mm  
7.87 · 9 inch

**RULLER**  
**TRACK ROLLERS**

→ 5

**OSCILLERENDE RULLER**  
**ROCKING ROLLERS**

JA  
YES

**REGULERING LARVEBÅND**  
**TRACKING TENSIONER**

JA  
YES

**HASTIGHED AF TVÆRGÅENDE BEVÆGELSE**  
**TRAVEL SPEED**

6 km/t  
3.7 mp/h

**DRIFTSKAPACITET**  
**OPERATING WEIGHT**

→ 1200 · 1500 kg / 2645 · 3306 lbs

**HIGH-TIP**

→ 900 · 1000 kg / 1984 · 2204 lbs

**TOMVÆGT**

**EMPTY WEIGHT**

950 · 1000 kg  
2094 · 2204 lbs

**STYRING**  
**CONTROL**

→ MONOJOYSTICK

**TEKNISKE SPECIFIKATIONER / TECHNICAL FEATURES**



FYLDT TIL RANDEN  
0,50 m<sup>3</sup>  
STRUCK 0.65 yd<sup>3</sup>

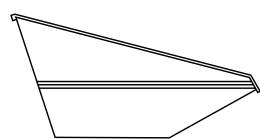

FYLDT OVER RANDEN  
0,65 m<sup>3</sup>  
HEAPED SAE 0.85 yd<sup>3</sup>

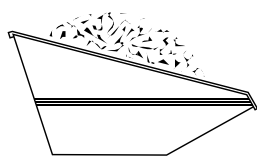

FYLDT TIL RANDEN  
0,38 m<sup>3</sup>  
STRUCK 0.49 yd<sup>3</sup>

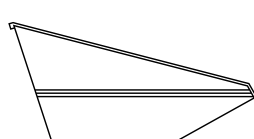

FYLDT OVER RANDEN  
0,5 m<sup>3</sup>  
HEAPED 0.65 yd<sup>3</sup>

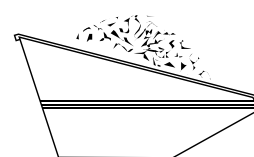

**KAPACITET / CAPACITY**





Data, beskrivelser og illustrationer i denne brochure er vejledende og ikke bindende. C&F srl forbeholder sig ret til at foretage ændringer og specifikationer uden forudgående varsel. Tilbehør monteres kun på forespørgsel.



**C&F SRL**

Viale Finlandia 8  
73100 Lecce, IT  
VAT 036 19 66 07 50  
+39 0832 24 39 60

•  
[www.cfequipments.com](http://www.cfequipments.com)  
[info@cfequipments.com](mailto:info@cfequipments.com)



**Erendfred Pedersen A/S**

Reblsagervej 7  
DK 9000 Aalborg  
Tlf 70 26 77 22

•  
[www.ep.dk](http://www.ep.dk)  
[info@ep.dk](mailto:info@ep.dk)

**EP Kolding**

Albuen 26  
6000 Kolding

**EP København**

Baldersbuen 22  
2640 Hedehusene